

## Data Sheet

# Thermostatic sensor RAS-C<sup>2</sup> with RA-N Presetting Valve

### Application



RAS-C<sup>2</sup> thermostatic sensor



RA-FN angle valve



RA-FN straight valve

The RAS-C<sup>2</sup> thermostatic sensor and the RA-N valves are designed for use in 2-pipe domestic heating systems.

**The RAS-C<sup>2</sup> thermostatic sensor** is a self-actuating proportional controller with a small P-band. It has a temperature range from 8 to 28° C and is equipped with frost protection setting and positive shut-off for maximum user flexibility.

**RA-N presetting valves** are manufactured from brass with nickel plating. The gland seal pressure pin is of chromium steel and works in a lifetime lubricated O-ring. The complete gland seal assembly can be replaced without draining down the system.

In order to avoid deposition and corrosion the composition of the hot water must be in accordance with the VDI 2035 guideline (Verein Deutscher Ingenieure). It is recommended that formulations containing mineral oil are avoided. Each RA-N valve body is supplied with a red protective cap, which can be used for manual regulation during the construction phase. The protective cap must not be used as a manual shut off device. A special manual shut off device is available as an accessory.

A comprehensive range of compression fittings for PEX, AluPEX, copper and steel tubes are available - please require special data sheet for Danfoss compression fittings.

### Approvals and Standards



#### European Standard EN 215

Thermostatic sensors RAS-C<sup>2</sup> with RA-N presetting valves are manufactured to the highest standards, and are approved to the European standard EN 215.

**Ordering and Specifications**
**RAS-C<sup>2</sup> thermostatic sensor**

Type	Design	Setting range <sup>1)</sup>	Code no.
RAS-C <sup>2</sup>	Built-in sensor, frost protection, positive shut-off	8 - 28 °C	013G6040

**RA-N radiator valves**

Type	Design	Connections		Presetting									Max. work. temp. °C	Code no
		Inlet	Out-let	$k_v$ -max. <sup>1)</sup> (m <sup>3</sup> /h at $\Delta p = 1$ bar)										
		Rp	R	1	2	3	4	5	6	7	N	N		
RA-N 10	Angle	3/8	3/8	0.04	0.08	0.11	0.18	0.21	0.28	0.31	0.43	0.65	120	013G0011
	Straight													013G0012
RA-N 15	Angle	1/2	1/2	0.04	0.08	0.12	0.18	0.25	0.32	0.38	0.53	0.90	120	013G0013
	Straight													013G0014
RA-N 20	Angle	3/4	3/4	0.09	0.14	0.18	0.25	0.31	0.40	0.51	0.71	1.40	120	013G0015
	Straight													013G0016
RA-N 25	Angle	1	1	0.09	0.14	0.18	0.25	0.31	0.40	0.51	0.71	1.40	120	013G0037
	Straight													013G0038

**Technical data**

Max. working pressure: 10 bar, max. diff. (2) pressure: 0.6 bar, test pressure: 16 bar Max working temperature 120°C

- 1) The  $k_v$ -value indicates the water flow (Q) in m<sup>3</sup>/h at a pressure drop ( $\Delta p$ ) across the valve of 1 bar;  

$$k_v = \frac{Q}{\sqrt{\Delta p}}$$
At setting N the  $k_v$ -value is stated according to EN 215, at XP = 2K i.e. the valve is closed at 2°C higher room temperature. At lower settings the XP value is reduced to 0.5K of the setting value 1. The  $k_{vs}$ -value states the flow Q at a maximum lift, i.e. at fully open valve at setting N.
- 2) Working pressure = static + differential pressure. The maximum differential pressure specified is the maximum pressure at which the valves give satisfactory regulation. As with any device which imposes a pressure drop in the system, noise may occur under certain flow/pressure conditions. To ensure quiet operation, maximum pressure drop should not exceed 30 to 35 kPa. The differential pressure can be reduced by the use of the Danfoss differential pressure regulators types AVD, AVDL, AVDS, IVD or ASV-P.

**Accessoires**

Product	Dimension	For valve body	Code no.
Gland seal (10pcs.)	-	All RA-N valves	013G0290
Compression fitting for steel and copper tubes (10pcs.)	Rp 3/8 x Ø10 mm	RA-N 10	013G4100
	Rp 3/8 x Ø12 mm		013G4102
	Rp 1/2 x Ø10 mm	RA-N 15	013G4110
	Rp 1/2 x Ø12 mm		013G4112
	Rp 1/2 x Ø15 mm		013G4115

Capacities

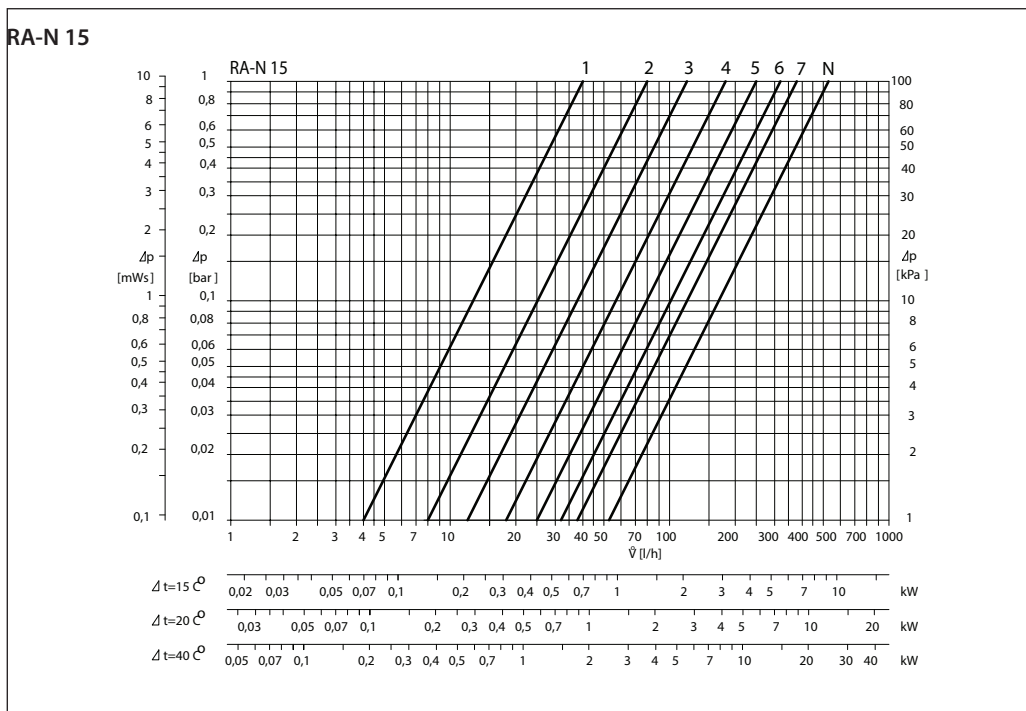
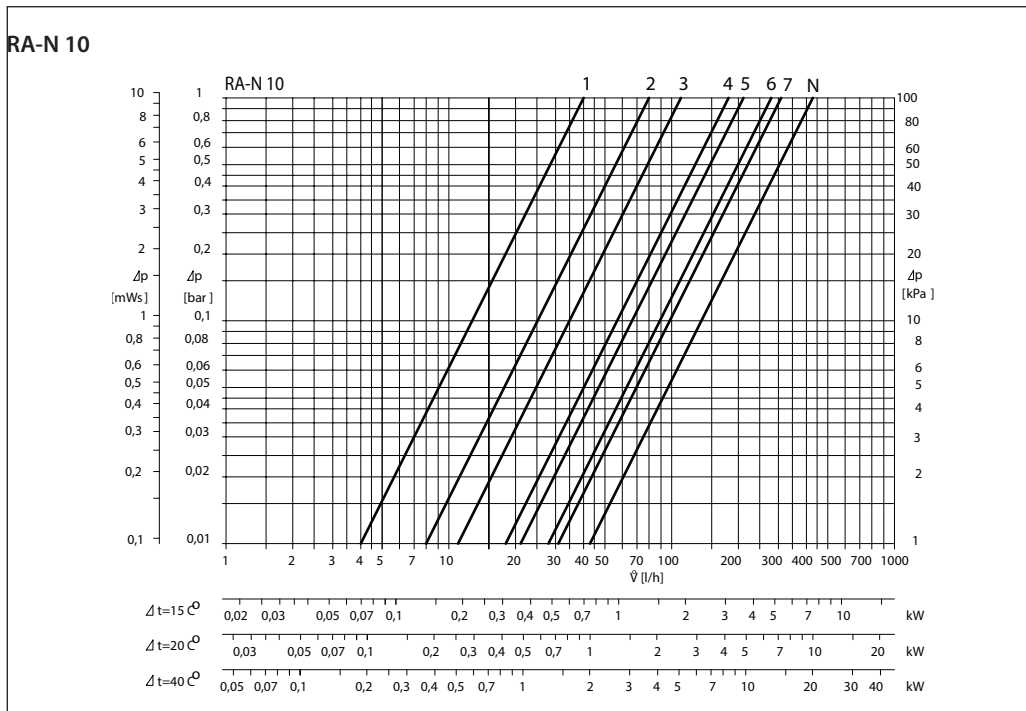

Capacities

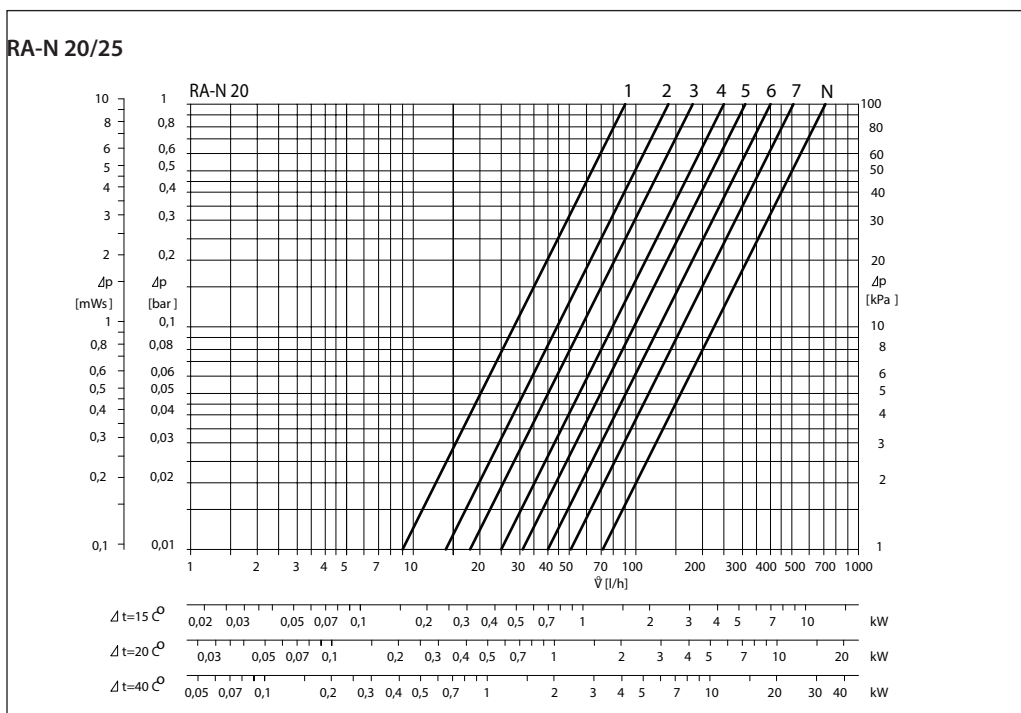

Sizing example

Required heat:		0.7kW
Cooling across radiator:		20°C
Flow through radiator:	$Q = \frac{0.7}{20 \times 1.16}$	=0.03m <sup>3</sup> /h=0.0083 l/s
Pressure drop across valve:		$\Delta p = 1 \text{ mwg}$
Valve setting:	RA-N10	3
	RA-N15	3
	RA-N 20/25	4

Alternatively the setting can be read directly in the table "Ordering and Specifications":

$$k_v = \frac{Q: (m^3/h)}{\sqrt{\Delta p (bar)}}$$

Note:

As with any device which imposes a pressure drop in the system, noise may occur under certain flow/ pressure conditions.

To ensure quiet operation, maximum pressure drop should not exceed 30 - 35 kPa (3 - 3.5 mwg).

Presetting

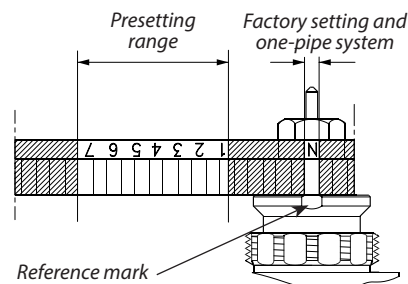
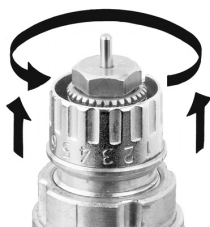

The presetting values of RA-N valves can be adjusted easily and accurately without the use of tools (factory setting = N):

- Remove protective cap/thermostatic sensor
- Find reference mark
- Lift and turn setting ring until the aquired presetting aligns with the reference mark.

Presetting can be selected in steps from 1 to 7.

At setting N the valve is fully open. This setting can be used as a flushing position, if the system has to be flushed out because of dirt problems. In one-pipe installations, the setting N must be used.

Settings outside 1 to 7 and N should be avoided.

When the thermostatic sensor has been installed, the presetting is protected against unintended regulation.

Design

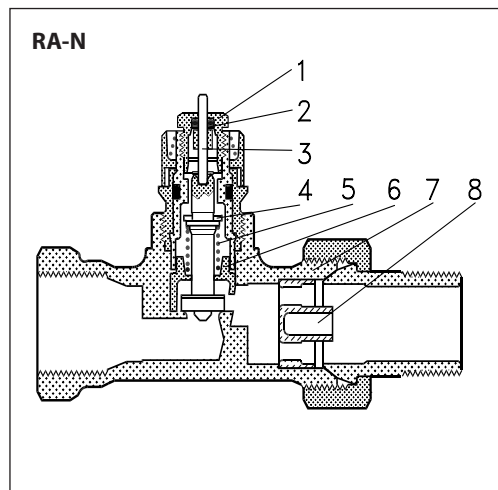
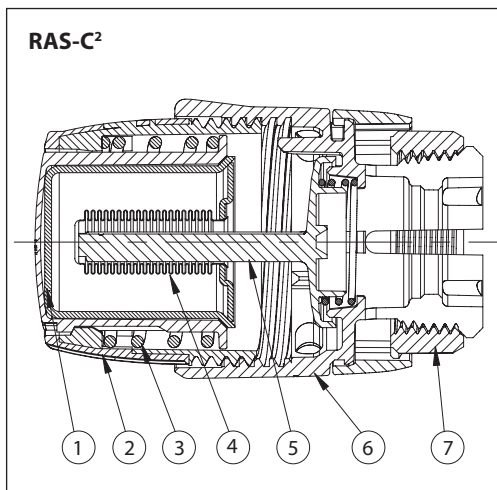

- 1. Actuator
- 2. Setting dial
- 3. Safety spring
- 4. Bellows
- 5. Spindle
- 6. Socket
- 7. Union nut

- 1. Gland seal
- 2. O-Ring
- 3. Pressure pin
- 4. Seal
- 5. Regulation spring
- 6. Setting dial
- 7. Valve body
- 8. k<sub>v</sub>-nozzle

Dimensions

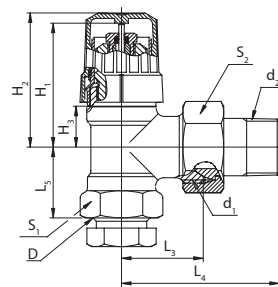
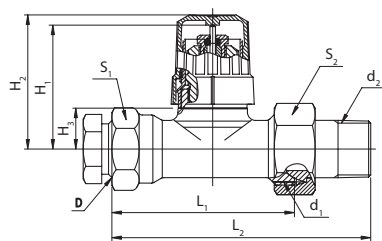
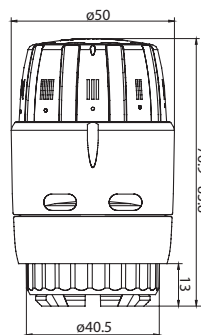

Type	ISO 7-1			L <sub>1</sub>	L <sub>2</sub>	L <sub>3</sub>	L <sub>4</sub>	L <sub>5</sub>	L <sub>7</sub>	Arc. flats	
	D	d <sub>1</sub>	d <sub>2</sub>							S <sub>1</sub>	S <sub>2</sub>
RA-N 10	G 3/8	G 5/8 A	R 3/8	50	75	24	49	20	91.9 - 98.8	22	27
RA-N 15	G 1/2	G 3/4 A	R 1/2	55	82	26	53	23	91.9 - 98.8	27	30
RA-N 20	G 3/4	G 1 1/4 A	R 3/4	65	98	30	63	26	96.9 - 103.8	32	37
RA-N 2	G 1 1/2	G 5/4 A	R 1 1/2	90	123	40	75	34	96.9 - 103.8	41	46

Danfoss A/S

Climate Solutions • danfoss.com • +45 7488 2222

Any information, including, but not limited to information on selection of product, its application or use, product design, weight, dimensions, capacity or any other technical data in product manuals, catalogues descriptions, advertisements, etc. and whether made available in writing, orally, electronically, online or via download, shall be considered informative, and is only binding if and to the extent, explicit reference is made in a quotation or order confirmation. Danfoss cannot accept any responsibility for possible errors in catalogues, brochures, videos and other material. Danfoss reserves the right to alter its products without notice. This also applies to products ordered but not delivered provided that such alterations can be made without changes to form, fit or function of the product. All trademarks in this material are property of Danfoss A/S or Danfoss group companies. Danfoss and the Danfoss logo are trademarks of Danfoss A/S. All rights reserved.