

Data sheet

Flow controller (PN 16, 25, 40) AFQ 2 / VFQ 2(1) – return and flow mounting

Description



The controller has a control valve with adjustable flow restrictor and an actuator with one control diaphragm.

- Further on two valve versions are available:
- VFQ 2 with metallic sealing cone
 - VFQ 21 with soft sealing cone (on special request)

Main data:

- DN 15-250
- k_{vs} 4.0-400 m³/h
- Flow range: 0.1-250 m³/h
- PN 16, 25, 40
- Flow restrictor Δp_b : 0.2 bar or 0.5 bar
- Temperature:
 - Circulation water / glycolic water up to 30 %: 2 ... 150/200 °C
- Connections:
 - Flange

The controller is a self-acting flow controller primarily for use in district heating systems. The controller closes when set max. flow is exceeded.

Ordering

Example 1:
Flow controller; DN 15; k_{vs} 4.0; PN 16; metallic sealing; flow restrictor Δp_b 0.2 bar; T_{max} 150 °C; flange;

- 1x VFQ 2 DN 15 valve
Code no: **065B2654**
- 1x AFQ 2 actuator
Code no: **003G5600**
- 1x AFQ 2 DN 15 impulse tubes
Code no: **003G1824***
- 1x Adapter VFQ 2 - AFx 2
Code no: **003G1780**

Products will be delivered separately.

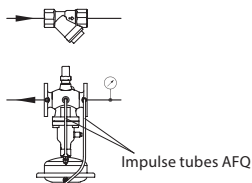

* To be available in Q3 2025.
Until then, 2x Impulse tube set AF (Code no: 003G1391) shall be ordered

VFQ 2 Valves (metallic sealing cone)

Picture	DN (mm)	k_{vs} (m ³ /h)	Connections	T_{max} (°C)	Code No.	T_{max} (°C)	Code No.	
					PN 16		PN 25	PN 40
	15	4.0	Flanges acc. to EN 1092-1	150	065B2654	200 ¹⁾	065B2667	065B2677
	20	6.3			065B2655		065B2668	065B2678
	25	8.0			065B2656		065B2669	065B2679
	32	16			065B2657		065B2670	065B2680
	40	20			065B2658		065B2671	065B2681
	50	32			065B2659		065B2672	065B2682
	65	50			065B2660		065B2673	065B2683
	80	80			065B2661		065B2674	065B2684
	100	125			065B2662		065B2675	065B2685
	125	160			065B2663		065B2676	065B2686
	150	280	Flanges acc. to EN 1092-1	150	065B2664	150	-	065B2687
	200	320		065B2758	-	065B2688		
	250	400		065B2759	-	065B2689		

Note: other valves available on special request.
¹⁾ at temperatures above 150 °C only with seal pots (see Accessories)

AFQ 2 Actuator

Picture	Δp setting range (bar)	Possible combinations with DN								Actuator size (cm ²)	Code No.	
		15-50	65	80	100	125	150	200	250		PN 16	PN 40
	0,2	✓	✓	✓	✓	✓	-	-	-	160	003G5600	003G5602
	0,5	✓	✓	✓	✓	✓	-	-	-		003G5601	003G5603
	0,2	-	-	-	-	-	✓	✓	✓	320	003G5596	003G5598
	0,5	-	-	-	-	-	✓	✓	✓		003G5597	003G5599

Ordering (continuous)

Example 2:
Flow controller; DN 15; k_{vs} 4.0; PN 25; metallic sealing; flow restrictor Δp_0 0.2 bar; T_{max} 200 °C; flange;

- 1x VFQ 2 DN 15 valve
Code no: **065B2667**
- 1x AFQ 2 actuator
Code no: **003G5602**
- 2x AFQ DN 15 impulse tubes
Code no: **003G1391**
- 2x Seal pot V1
Code no: **003G1392**
- 1x Adapter VFQ 2 - AFx 2
Code no: **003G1780**

Products will be delivered separately.

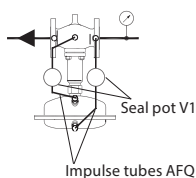
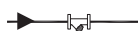

Accessories

Picture	Type designation	For controller	DN (mm)	PN	Code No.
	Impulse tubes ¹⁾ (Stainless steel)	AFQ 2	15	16, 25, 40	003G1820²⁾
			20		003G1821²⁾
			25		003G1822²⁾
			32		
			40		
	Impulse tube set AF (Cooper tube)		50	16, 25, 40	003G1823²⁾
			65		003G1391 (2x)
			80		
			100		
			125		
			150		
			200		
			250		

¹⁾ With combination piece KF2 or KF3 use 2x 003G1391

²⁾ Impulse tube sets to be available in Q3 2025

Accessories

Picture	Type designation	Description	Ordering number		Code No.
	Impulse tube set AF	- 1x Copper tube Ø10 x 1 x 1500 mm - 1 x compression fitting for imp. tube connection to pipe (G 1/4) - 2 x socket	DN 15-150	2x	003G1391
			DN 200, 250	3x	
	Seal pot V1 ¹⁾	Capacity 1 liter; with compression fittings for imp. tube Ø10	AFQ	2x	003G1392
	Compression fitting ²⁾	For impulse tube Ø10 connections to controller	G 1/4		003G1468
	Combination piece KF3	For combination with pressure actuators. Electrical actuator connected on side (port B) only for ON/OFF function	G 1 1/4 / 2x G 1 1/4		003G1441
	Combination piece KF2	For combination with thermostat - side connection to port B			003G1440
	Shut off valve	For impulse tube Ø10	-		003G1401
	Throttle valve				065B2909
	Adapter	For combination of new Virtus pressure actuators AFx 2, with old generation of valves VFx 2 (DN15-250)	-		003G1780

¹⁾ Seal pot has to be used on impulse tubes always when $T_{max} \geq 150$ °C

²⁾ Consist of a nipple, compression ring and nut

³⁾ Port A - for connection of any type of actuator

Service kits

Picture	Type designation	For valve	DN (mm)	k_{vs} (m ³ /h)	Code No.
	Valve insert	VFQ 2	15	4.0	065B2796
			20	6.3	065B2797
			25	8	065B2798
			32	16	
			40	20	065B2799
			50	32	
			65	50	065B2800
			80	80	
			100	125	065B2801
			125	160	
			150	280	065B2964
250	400	065B2965			
	Stuffing cone (with EPDM O-rings)				003G1464

Technical data

Valve

Nominal diameter			DN	15	20	25	32	40	50	65	80	100	125	150	200	250		
k _{vs} value of Δp regulator				4.0	6.3	8.0	16	20	32	50	80	125	160	280	320	400		
Range of max. flow setting	Δp _b ¹⁾ = 0.2 bar	from	m ³ /h	0.1	0.2	0.2	0.4	0.6	0.8	3	4	6	8	12	15	18		
		to		2	3	4	7	11	16	28	40	63	80	125	150	180		
	Δp _b ¹⁾ = 0.5 bar	from		0.2	0.3	0.3	0.5	0.8	1.2	4	6	9	12	18	22	25		
		to		3	4.5	6	10	16	24	40	58	90	120	180	220	250		
Cavitation factor z				0.6	0.6	0.6	0.55	0.55	0.5	0.5	0.45	0.4	0.35	0.3	0.2	0.2		
Leakage acc. to standard IEC 534 (% of k _{vs})			VFQ 2	≤0.03											≤0.05			
			VFQ 21	≤0.01														
Nominal pressure			PN	16, 25, 40														
Min. differential pressure for max flow ²⁾	Δp _b ¹⁾ = 0.2	bar	0.5	0.4	0.5	0.4	0.5					0.4						
	Δp _b ¹⁾ = 0.5		0.8	0.7	0.8	0.7	0.8					0.7						
Max. differential pressure	PN 16		16											15	12	10		
	PN 25, 40		20															
Media			Circulation water / glycolic water up to 30 %															
Media pH			Min. 7, max. 10															
Media temperature	VFQ 2	°C	2 ... 150 / 2 ... 200 ²⁾											2 ... 150				
	VFQ 21		2 ... 150															
Connections			Flange															
Materials																		
Valve body	PN 16	Grey cast iron EN-GJL-250 (GG-25)																
	PN 25	Ductile iron EN-GJS-400(GGG-40.3)																
	PN 40	Cast steel GP240GH (GS-C 25)																
Valve seat			Stainless steel, mat. No. 1.4021											Stainless steel, mat. No. 1.4313				
Valve cone			Stainless steel, mat. No. 1.4404											Stainless steel, mat. No. 1.4021				
Sealing	VFQ 2	Metal																
	VFQ 21	EPDM																
Pressure relieve system			Bellows (Stainless steel, mat. No. 1.4571)											Diaphragm (EPDM)				

¹⁾ Δp_b – differential pressure over flow restrictor

²⁾ For flows smaller than Q_{max} → Δp_{min} = $\left(\frac{Q}{k_{vs}}\right)^2 + \Delta p_b$

³⁾ at temperatures above 150 °C only with seal pots (see Accessories)

AFQ 2 Actuator

Actuator size	cm ²	160	320
Max. operating pressure	bar	16, 40	
Flow restrictor differential pressure Δp _b		0.2 / 0.5	
For valve DN		65-125	150-250
Materials			
Actuator housing		Steel, mat. No. 1.0345, zinc plated	
Control diaphragm		EPDM (Rolling; fibre enforced)	

Application principles

– Return mounting

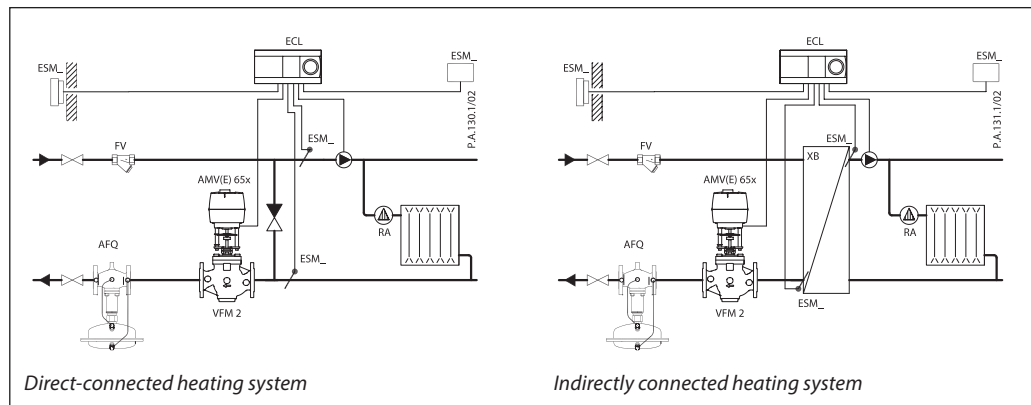

– Flow mounting

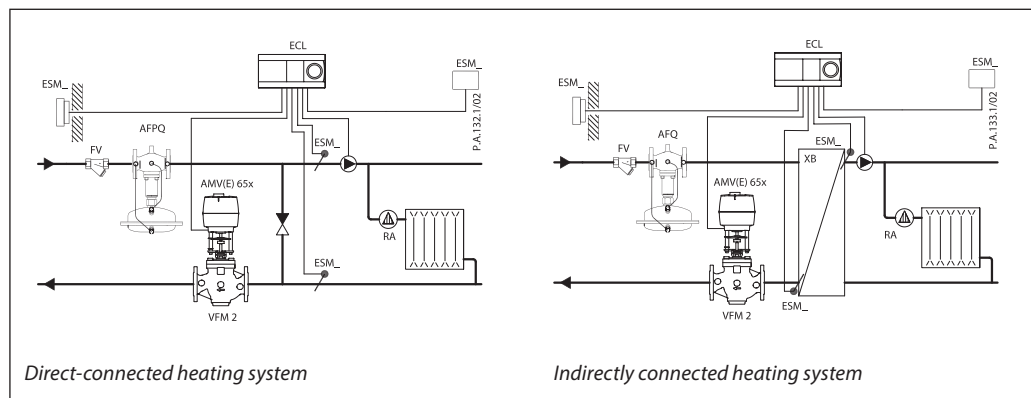

Combinations for Temperature Controller DN15-125

Example:
Flow temperature controller, return mounting; DN 15; k_{vs} 4.0; PN 16; metallic sealing; flow restrictor Δp_s 0.2 bar; T_{max} 150 °C; flange;

- 1x VFQ 2 DN 15 valve
Code no: **065B2654**
- 1x AFQ 2 actuator
Code no: **003G5600**
- 2x Impulse tube set AF
Code no: **003G1391**
- 1x AFT06 thermostat
Code no: **065-4390**
- 1x Combination piece KF2
Code no: **003G1440**
- 1x Adapter VFQ 2 - AFx 2
Code no: **003G1780**

Products will be delivered separately.

Note:
For AFT06 and STFW thermostats data see relevant data sheets

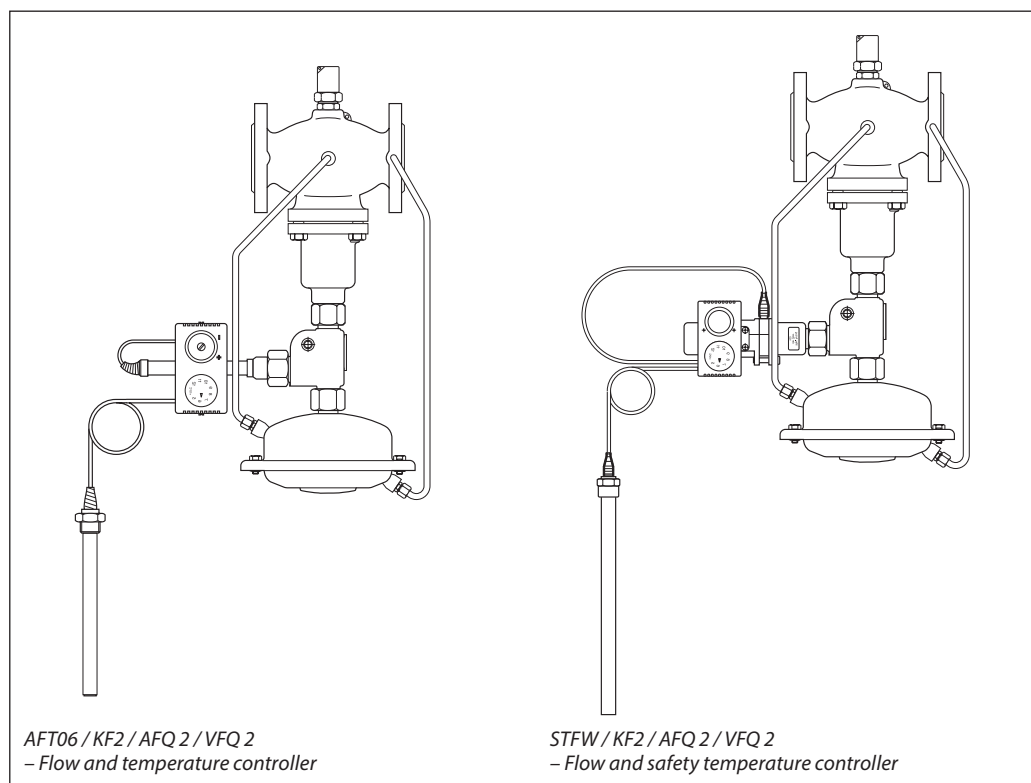

AFT06 / KF2 / AFQ 2 / VFQ 2
– Flow and temperature controller

STFW / KF2 / AFQ 2 / VFQ 2
– Flow and safety temperature controller

Installation positions

DN 15-80 $T_{max} \leq 120\text{ }^{\circ}\text{C}$

DN 15-80 $T_{max} > 120\text{ }^{\circ}\text{C}$; DN 100-250

The controllers can be installed in any position.

The controllers can be installed in horizontal pipes only, with a pressure actuator oriented downwards.

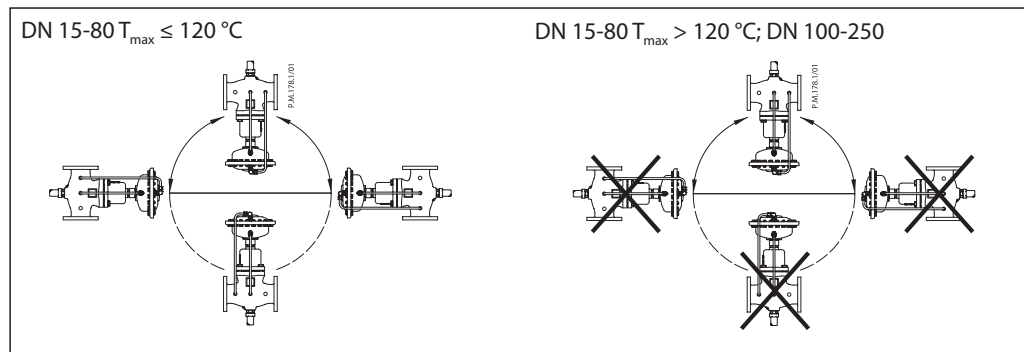

Pressure temperature diagram

Working area is below P-T line and it ends at T_{max} for each valve

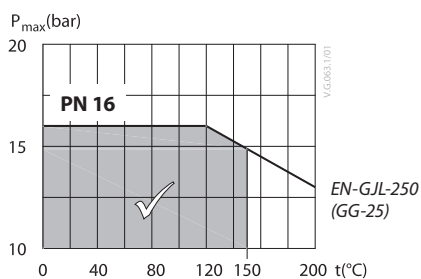

Maximum allowed operating pressure as a function of media temperature (according to EN 1092-2)

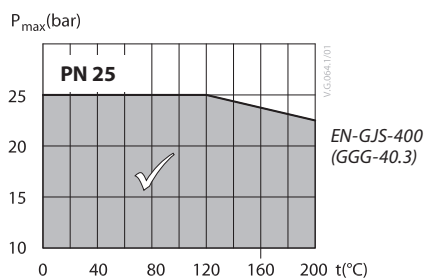

Maximum allowed operating pressure as a function of media temperature (according to EN 1092-2)

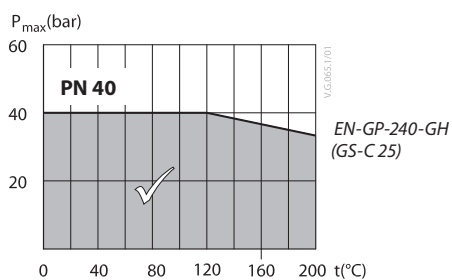

Maximum allowed operating pressure as a function of media temperature (according to EN 1092-1)

Sizing

- Directly connected heating system

Example 1

Motorised control valve (MCV) for mixing circuit in direct-connected heating system requires differential pressure of 0.3 bar (30 kPa) and flow less than 600 l/h.

Select controller from table, page 3, with the smallest possible k_{VS} value considering available flow ranges.

$$k_{VS} = 4.0 \text{ m}^3/\text{h}$$

Given data:

- $Q_{max} = 0.6 \text{ m}^3/\text{h}$ (600 l/h)
- $\Delta p_{min} = 0.9 \text{ bar}$ (90 kPa)
- $\Delta p_{circuit}^{1)} = 0.1 \text{ bar}$ (10 kPa)
- $\Delta p_{MCV} = 0.3 \text{ bar}$ (30 kPa) selected
- $\Delta p_b^{2)} = 0.2 \text{ bar}$ (20 kPa)

The min. required differential pressure across the selected controller is calculated from the formula:

$$\Delta p_{AFQ,MIN} = \left(\frac{Q_{max}}{k_{VS}} \right)^2 + \Delta p_b = \left(\frac{0.6}{4} \right)^2 + 0.2$$

Remark:

- ¹⁾ $\Delta p_{circuit}$ corresponds to the required pump pressure in the heating circuit and is not to be considered when sizing the AFQ.
- ²⁾ Δp_b is differential pressure over flow restrictor.

$$\Delta p_{AFQ,MIN} = 0.22 \text{ bar} \text{ (22 kPa)}$$

$$\Delta p_{AFQ,A} > \Delta p_{AFQ,MIN}$$

The total (available) pressure loss across the controller is:

$$0.6 \text{ bar} > 0.22 \text{ bar}$$

$$\Delta p_{AFQ,A} = \Delta p_{min} - \Delta p_{MCV} = 0.9 - 0.3$$

$$\Delta p_{AFQ,A} = 0.6 \text{ bar} \text{ (60 kPa)}$$

Solution:

The example selects AFQ DN 15; k_{VS} value 4.0; flow setting range 0.1-2.0 m^3/h .

Possible pipe pressure losses in tubes, shut-off fittings, heatmeters, etc. are not included.

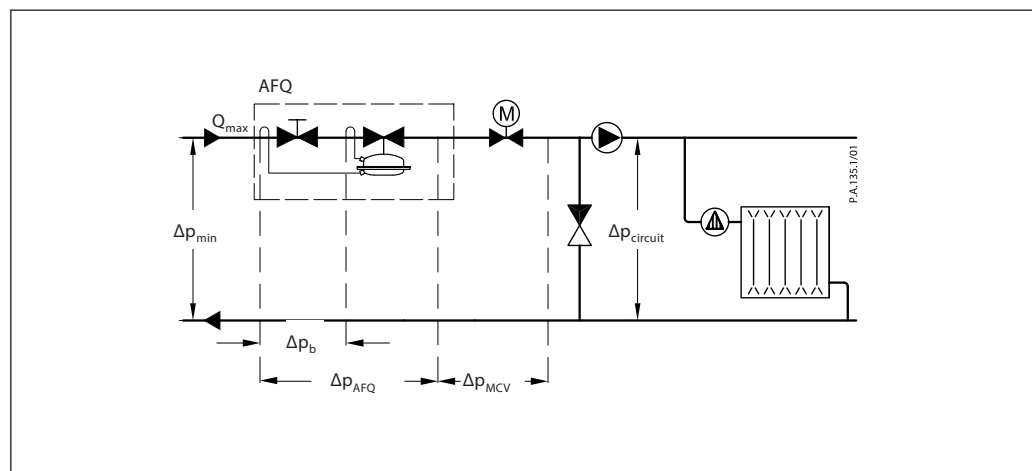
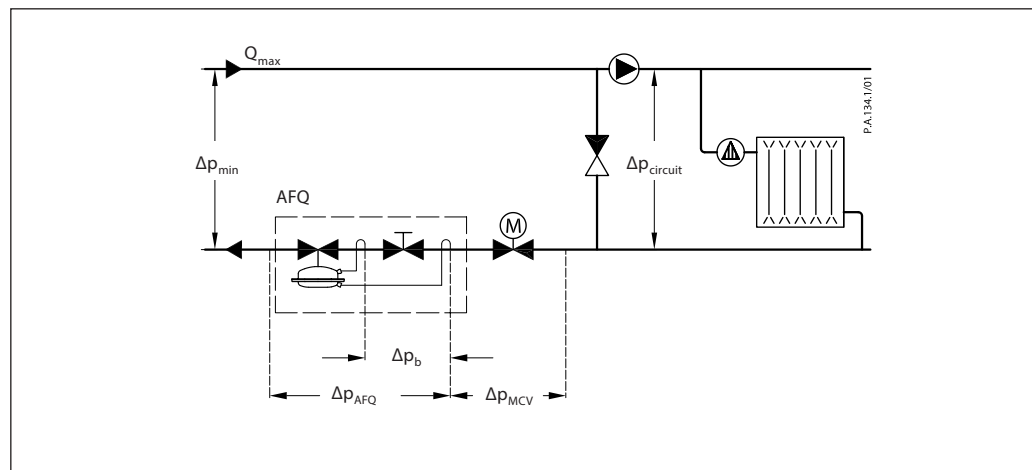

Sizing (continuous)

– Indirectly connected heating system

Example 2

Motorised control valve (MCV) for indirectly connected heating system requires differential pressure of 0.3 (30 kPa) bar and flow less than 1900 l/h.

Given data:

- $Q_{max} = 1.9 \text{ m}^3/\text{h}$ (1900 l/h)
- $\Delta p_{min} = 1.1 \text{ bar}$ (110 kPa)
- $\Delta p_{exchanger} = 0.1 \text{ bar}$ (10 kPa)
- $\Delta p_{MCV} = 0.3 \text{ bar}$ (30 kPa) selected
- $\Delta p_b^{1)} = 0.2 \text{ bar}$ (20 kPa)

Remark:

¹⁾ Δp_b is differential pressure over flow restrictor

The total (available) pressure loss across the controller is:

$$\begin{aligned} \Delta p_{AFQ,A} &= \Delta p_{min} - \Delta p_{exchanger} - \Delta p_{MCV} \\ &= 1.1 - 0.1 - 0.3 \\ \Delta p_{AFQ,A} &= 0.7 \text{ bar (70 kPa)} \end{aligned}$$

Possible pipe pressure losses in tubes, shut-off fittings, heatmeters, etc. are not included.

Select controller from table, page 3, with the smallest possible k_{VS} value considering available flow ranges.

$$k_{VS} = 4.0 \text{ m}^3/\text{h}$$

The min. required differential pressure across the selected controller is calculated from the formula:

$$\Delta p_{AFQ,MIN} = \left(\frac{Q_{max}}{k_{VS}} \right)^2 + \Delta p_b = \left(\frac{1.9}{4.0} \right)^2 + 0.2$$

$$\Delta p_{AFQ,MIN} = 0.43 \text{ bar (43 kPa)}$$

$$\Delta p_{AFQ,A} > \Delta p_{AFQ,MIN}$$

$$0.7 \text{ bar} > 0.43 \text{ bar}$$

Solution:

The example selects AFQ; DN 15; k_{VS} value 4.0; flow setting range 0.1-2.0 m^3/h .

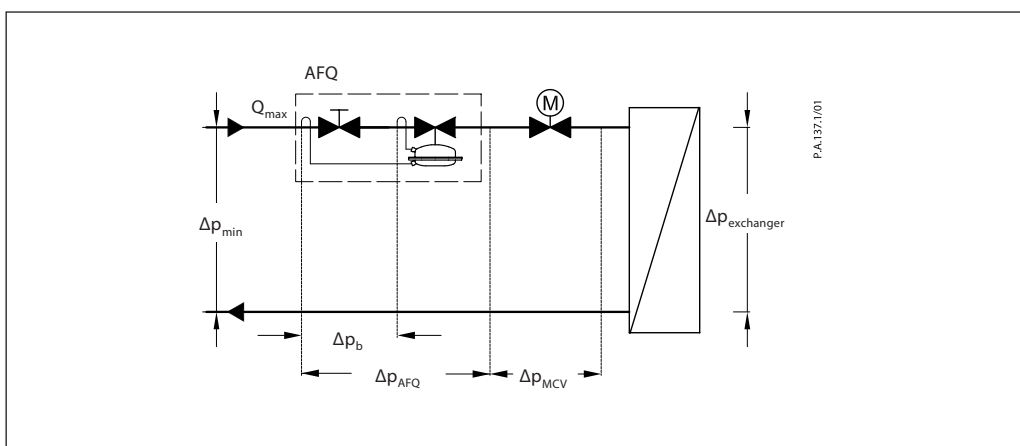
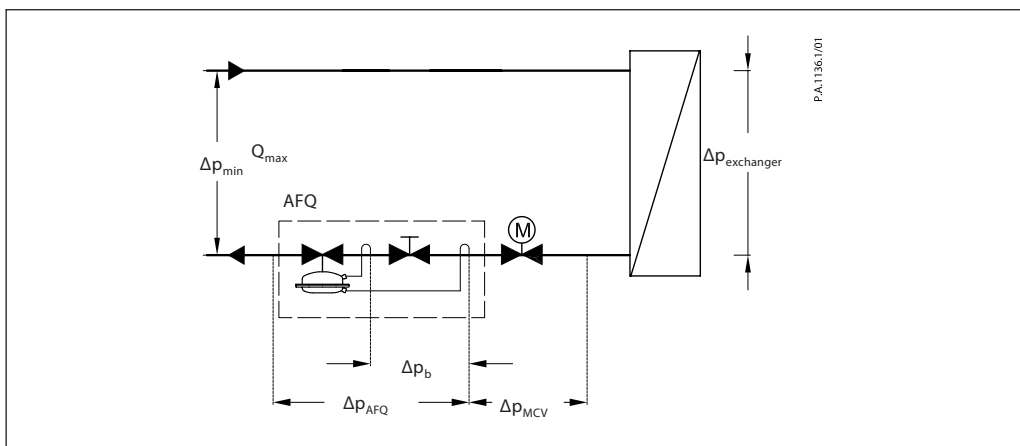

Design

1. Valve body
2. Cover
3. Adjustable flow restrictor
4. Valve seat
5. Valve insert
6. Pressure relieved valve cone
7. Valve stem
8. Bellows for pressure relief of valve cone
9. Diaphragm for pressure relief of valve cone
10. Actuator
11. Control diaphragm for flow control
12. Built-in spring for flow control
13. Stuffing cone
14. Union nut
15. Impulse tube
16. Compression fitting for impulse tube
17. Upper casing of diaphragm
18. Lower casing of diaphragm
19. Valve body extension
20. Shut off valve for water filling
21. Closing plug

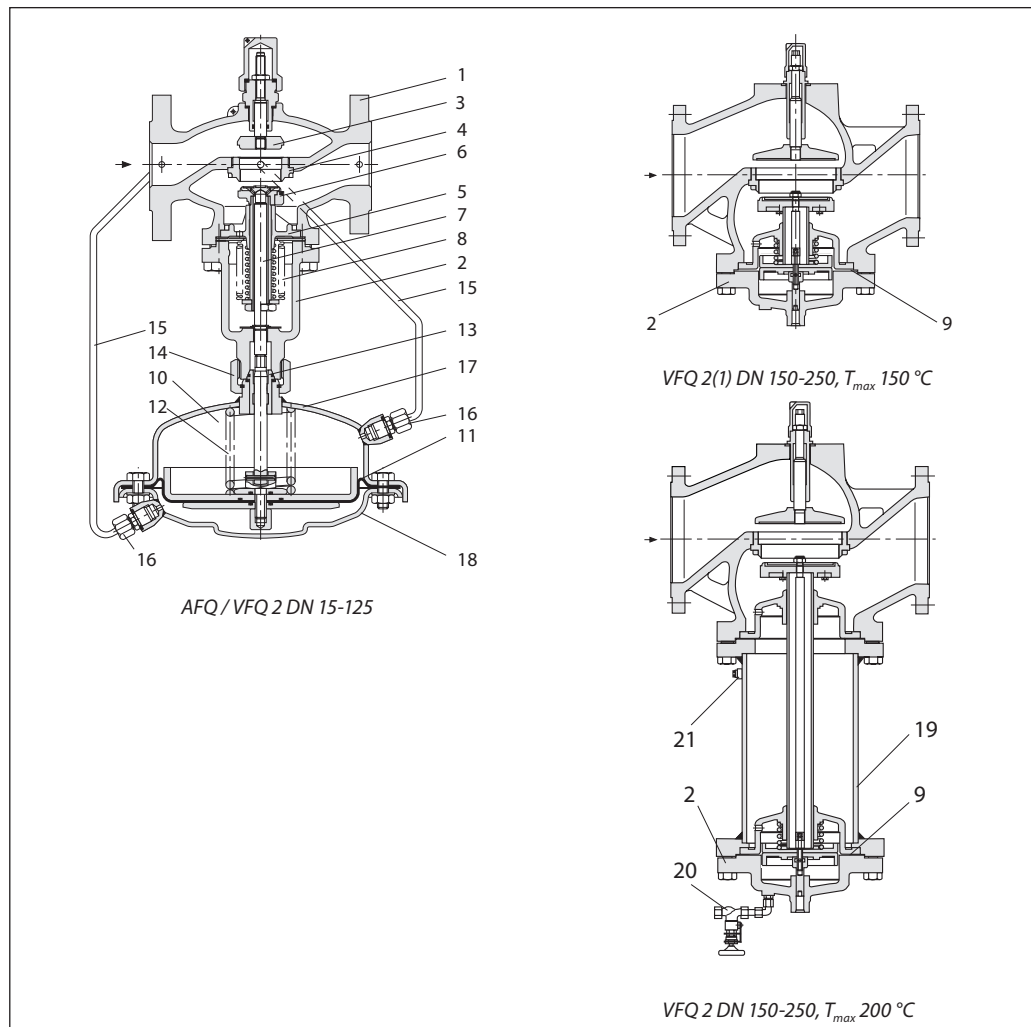

Function

Flow volume causes pressure drop across the adjustable flow restrictor. Resulting pressures are being transferred through the impulse tubes to the actuator chambers and act on control diaphragm for flow control. The flow restrictor diff. pressure is controlled and limited by means of built-in spring for flow rate control. Control valve closes on rising differential pressure and opens on falling differential pressure to control max flow.

Settings

Flow setting

Flow setting is being done by the adjustment of the flow restrictor position. The adjustment can be performed on the basis of flow adjustment diagram (see relevant instructions) and/or by the means of heat meter.

Dimensions

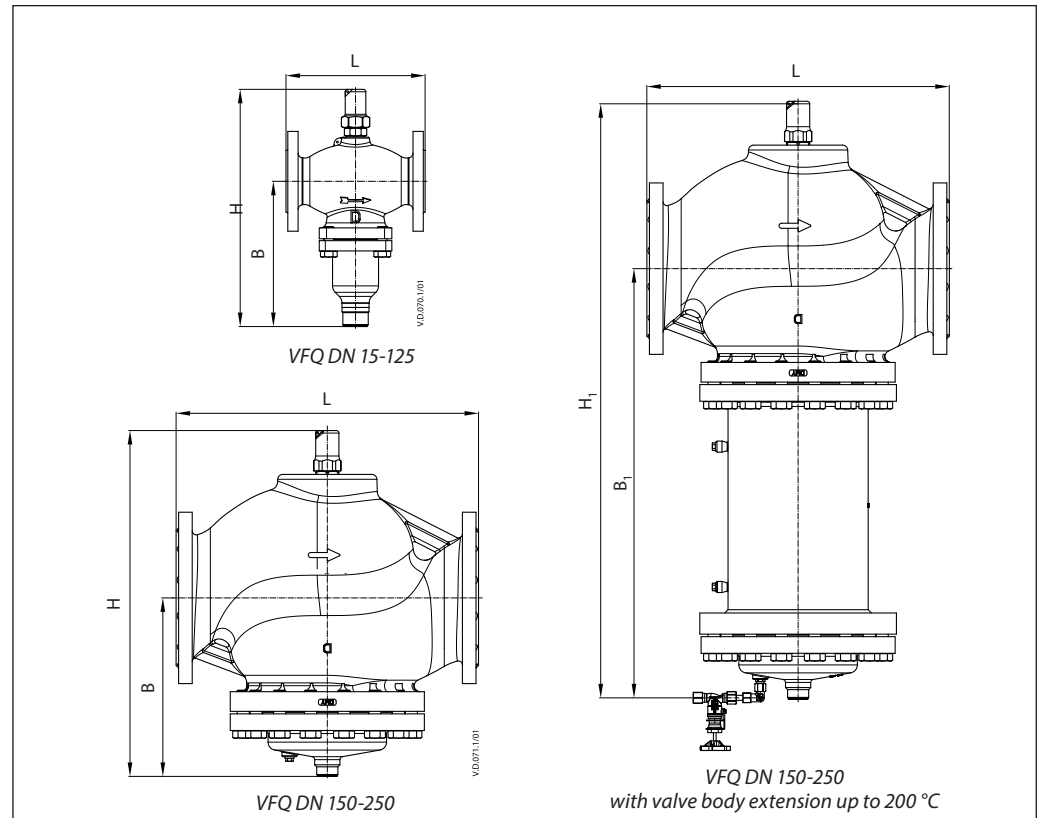

VFQ 2, VFQ 21 Valves

DN		15	20	25	32	40	50	65	80	100	125	150	200	250
L		130	150	160	180	200	230	290	310	350	400	480	600	730
B	mm	213	213	239	239	241	241	276	276	381	381	326	354	401
H		337	337	374	374	393	393	440	440	575	575	595	686	756
Weight	PN 16 / 25	8	9	10.5	12.5	15.5	18.5	28.5	31	61	71	120	193	337
	PN 40							31	34	63	72	147	264	347
B ₁	mm											620	852	1199
H ₁												889	1184	1555
Weight (valve with body extension)	PN 16 / 25											160	314	489
	PN 40											187	350	526

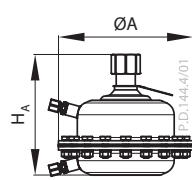

AFQ 2 Actuator

AFQ 2 Actuator

Size	ØA	H _A	Weight	
			PN 16	PN 40
cm ²	mm		kg	
160	230	200	8	10
320	300	200	13	19

Total installation height of the controller (VFQ 22(1) valve + AFQ 2 pressure actuator) is sum of H_v and H_A

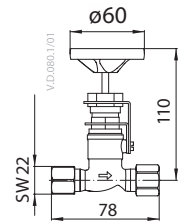

Shut off valve

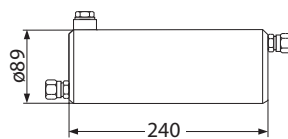

Seal pot V1

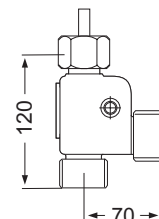

Comb. piece KF2, KF3

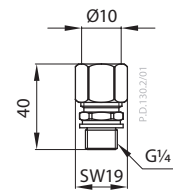

Compression fitting



Danfoss A/S

Climate Solutions • danfoss.com • +45 7488 2222

Any information, including, but not limited to information on selection of product, its application or use, product design, weight, dimensions, capacity or any other technical data in product manuals, catalogues descriptions, advertisements, etc. and whether made available in writing, orally, electronically, online or via download, shall be considered informative, and is only binding if and to the extent, explicit reference is made in a quotation or order confirmation. Danfoss cannot accept any responsibility for possible errors in catalogues, brochures, videos and other material. Danfoss reserves the right to alter its products without notice. This also applies to products ordered but not delivered provided that such alterations can be made without changes to form, fit or function of the product.

All trademarks in this material are property of Danfoss A/S or Danfoss group companies. Danfoss and the Danfoss logo are trademarks of Danfoss A/S. All rights reserved.